

FLOAT AND THERMOSTATIC STEAM TRAPS

FLT17 (DN 11/2" – 2"; DN 40 – 50)

DESCRIPTION

FLT17 float and thermostatic (integral air vent) steam traps series are designed for all types of low and high pressure steam heating and process equipment.

Typical applications include unit heaters, heat exchangers, driers, jacketed vessels and all the applications where continuous drainage is essential.

Connections are female screwed or flanged for horizontal or vertical installation.

MAIN FEATURES

Modulating discharge.

Discharges condensate at steam temperature.

Unaffected by sudden or wide load and pressure changes.

Excellent air discharge (by thermostatic air vent).

OPTIONS: SLR – steam lock release
Equalizing plug or vent connection

USE: Saturated and superheated steam.

AVAILABLE

MODELS: FLT17-4,5 , 10 and 14

SIZES: DN11/2" - DN2" ; DN40 – DN50

CONNECTIONS: Female screwed ISO7/1 Rp (BS21)
Flanged EN 1092-2 PN16 or ANSI

INSTALLATION: Standard horizontal installation –
From right to left FLT17 (R-L)

Upon request:

-horizontal installation with the flow from left to right (L-R)

-vertical installation with the flow from top to bottom (V)

MAX. DIFFERENTIAL PRESSURE

FLT17-4,5 : 4,5 bar

FLT17-10 : 10 bar

FLT17-14: 14 bar



BODY LIMITING CONDITIONS		
FLANGED PN16*	FLANGED ANSI 150 **	RELATED TEMP.
ALLOW. PRES.	ALLOW. PRES.	
16 bar	15,4 bar	100 °C
15,5 bar	14,6 bar	150 °C
14,7 bar	13,8 bar	200 °C
13,9 bar	12,1 bar	250 °C

PMO - Max. operating pressure 14 bar

TMO - Max. operating temperature 198 °C

* According to EN1092-2:2000 ; ** Acc. to EN1759-1:2004

Body limiting conditions PN16 or below, depending on the type of connection adopted. Rating PN16 for thread.

FLOW RATE CAPACITY IN Kgs/h										
MODEL	SIZE	DIFFERENTIAL PRESSURE (bar)								
		0,5	1	1,5	2	4,5	7	10	12	14
FLT17-4,5	40-50	2400	3400	3900	4500	7300				
FLT17-10	40-50	1500	2000	2600	3000	4000	5400	6200		
FLT17-14	40-50	950	1300	1600	1800	2600	3250	3900	4210	4950

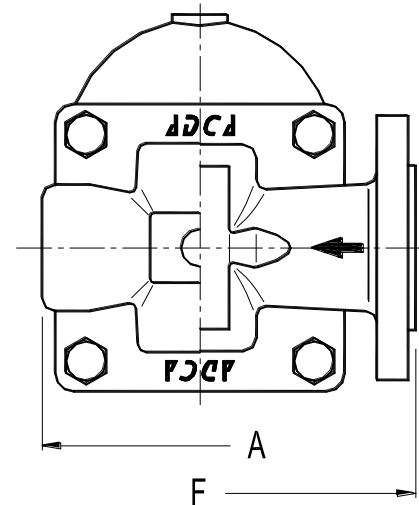
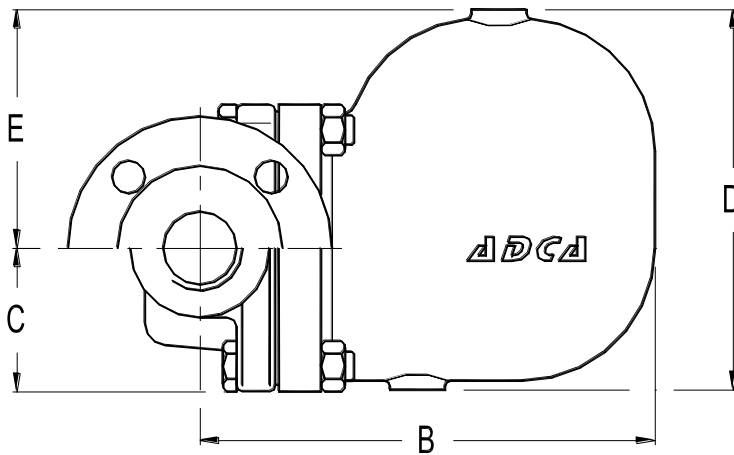

DIMENSIONS (mm)												
Screwed							EN PN16			ANSI 150		
SIZE DN	A	B	C	D	E	WGT. Kgs	F	B	WGT. Kgs	F	B	WGT. Kgs
40-11/2"	210	248	79	208	131	16,9	230	248	20,3	230	248	19,1
50-2"	210	248	79	208	131	17,5	230	248	20,7	230	248	20,5

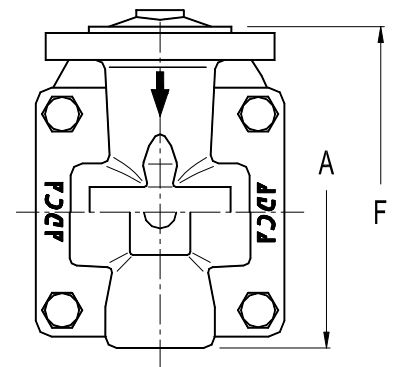
Vertical Installation (V)

MATERIALS		
POS.Nr.	DESIGNATION	MATERIAL
1	Body	GJS-400-15 / 0.7040
2	Cover	GJS-400-15 / 0.7040
3	*Gasket	Stainless st. / Graphite
4	*Seat	CF8 / 1.4308
5	*Valve	AISI 420 / 1.4021
6	*Lever	AISI 304 / 1.4301
7	*Float	AISI 304 / 1.4301
8	*Air vent	Stainless st. (Bimetallic)
9	Bolts	Steel 8.8

*Available spare parts.

